



MPPT Max PV input Voltage 75V **SOLAR CHARGE CONTROLLER**

Tracer Dream Series

12V/24V 15A 20A 30A 40A

Your battery guard

Dear users,

Thank you for choosing our product !

Important Safety Instructions

Please keep this manual for future review.

This manual contains all instructions of safety, installation and operation for Tracer Dream series Maximum Power Point Tracking (MPPT) controller ("the controller" as referred to in this manual).

General Safety Information

- ① Read carefully all the instructions and warnings in the manual before installation.
- ② No user serviceable components inside the controller. Don't disassemble or attempt to repair the controller.
- ③ Mount the controller indoors. Avoid exposure the components and do not allow water to enter the controller.
- ④ Install the controller in a well ventilated place. The controller's heat sink may become very hot during operation.
- ⑤ Suggest installing appropriate external fuses/breakers.
- ⑥ Make sure to switch off all PV array connections and the battery fuse or breakers before controller installation and adjustment.
- ⑦ Power connections must remain tight to avoid excessive heating from loose connection.

1. General Information

1.1 Overview

Tracer Dream 75V series controller is based on advanced MPPT control algorithm, with LCD displaying running status. The MPPT control algorithm can minimize the maximum power point loss rate and loss time, quickly track the maximum power point of the PV array and obtain the maximum energy from solar modules under any conditions; and can increase the ratio of energy utilization in the solar system by 20%-30% compared with a PWM charging method.

Limiting the charging power and reducing charging power functions ensure the system stable with over PV modules in high temperature environment.

With comprehensive electronic fault self-detecting functions and powerful electronic protection functions built inside the controller, component damage caused by installation errors or system failures can be avoided to the greatest extent possible.

Features:

- With the advanced dual-peak or multi-peak tracking technology, when the solar panel is shadowed or part of the panel fails resulting in multiple peaks on the I-V curve, the controller is still able to accurately track the maximum power point.
- Advanced MPPT technology, with efficiency no less than 99.5%
- Maximum DC/DC conversion efficiency of 98%
- Ultra-fast tracking speed and guaranteed tracking efficiency
- Advanced MPPT control algorithm to minimize the MPP loss rate and loss time
- Wide MPP operating voltage range
- Limit charging power & current over rated range. When the solar panel power exceeds a certain level and the charging current is larger than the rated current, the controller will automatically lower the charging power and bring the charging current to the rated level.
- Support the lead-acid, gel, flooded with the needed Temp. compensation and support lithium batteries start from solar panel
- Real-time working record function
- Power reduction automatically over temperature range
- Multiple load work modes
- TVS lighting protection.
- Monitor and set the parameters via App(optional)

1.2 Characteristics

- 1 Menu Button
- 2 Operation Button
- 3 Charging Indicator
- 4 LCD
- 5 Temperature Sensor
- 6 USB Port
- 7 Load Terminals
- 8 Battery Terminals
- 9 PV Terminals



Figure 1-1 Product Characteristics

★If the temperature sensor is short-circuited or damaged, the controller will charge or discharge at the default temperature setting of 25°C.

1.3 Naming Rules of Controller models

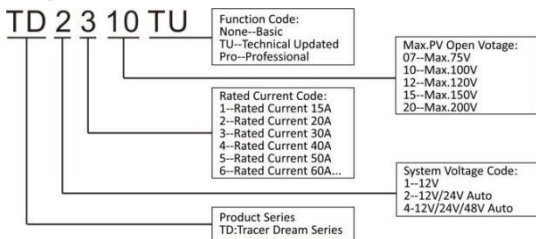

Figure 1-2 Example

1.4 Maximum Power Point Tracking Technology

Due to the nonlinear characteristics of solar array, there is a maximum energy output point (Max Power Point) on its curve. Traditional controllers, with switch charging technology and PWM charging technology, can't charge the battery at the maximum power point, so can't harvest the maximum energy available from PV array, but the solar charge controller with Maximum Power Point Tracking (MPPT) Technology can lock on the point to harvest the maximum energy and deliver it to the battery.

The MPPT algorithm of our company continuously compares and adjusts the operating points to attempt to locate the maximum power point of the array. The tracking process is fully automatic and does not need user adjustment.

As the Figure 1-2, the curve is also the characteristic curve of the array, the MPPT technology will 'boost' the battery charge current through tracking the MPP. Assuming 100% conversion efficiency of the solar system, in that way, the following formula is established:

$$\text{Input power (P}_{pv}\text{)} = \text{Output power}$$

$$\text{Input voltage (V}_{Mpp}\text{)} * \text{input current (I}_{pv}\text{)} = \text{Battery voltage (V}_{Bat}\text{)} * \text{battery current (I}_{Bat}\text{)}$$

Normally, the V_{Mpp} is always higher than V_{Bat} , Due to the principle of conservation of energy, the I_{Bat} is always higher than I_{pv} . The greater the discrepancy between V_{Mpp} & V_{Bat} , the greater the discrepancy between I_{pv} & I_{Bat} . The greater the discrepancy between array and battery, the bigger reduction of the conversion efficiency of the system, thus the controller's conversion efficiency is particularly important in the PV system.

Figure 1-3 is the maximum power point curve, the shaded area is charging range of traditional solar charge controller (PWM Charging Mode), it can obviously diagnose that the MPPT mode can improve the usage of the solar energy resource. According to our test, the MPPT controller can raise 20%-30% efficiency compared to the PWM controller. (Value may be fluctuant due to the influence of the ambient circumstance and energy loss.)

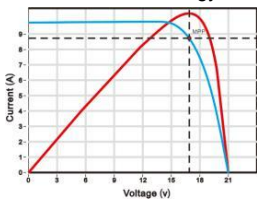

Figure 1-3 Maximum Power Point Curve

In actual application, as shading from cloud, tree and snow, the panel maybe appear Multi-MPP, but in actually there is only one real Maximum Power Point. As the below Figure 1-3 shows:

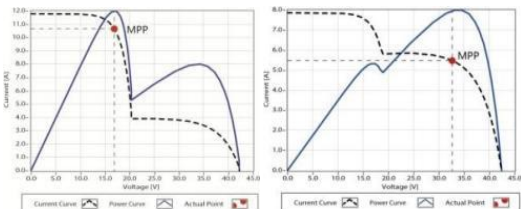

Figure 1-4 Mutli-MPP Curve

If the program works improperly after appearing Multi-MPP, the system will not work on the real max power point, which may waste most solar energy resources and seriously affect the normal operation of the system. The typical MPPT algorithm, designed by our company, can track the real MPP quickly and accurately, improve the utilization rate of the array and avoid the waste of resources.

1.5 Battery Charging Stage

The controller has a 3 stages battery charging algorithm (Bulk Charging, Boost Charging and Float Charging) for rapid, efficient, and safe battery charging.

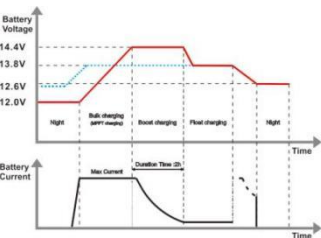

Figure 1-5 Lead acid Battery charging stage Curve

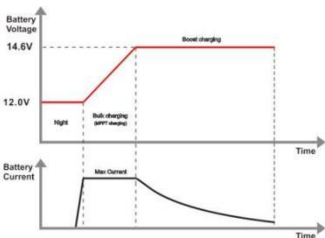

Figure 1-6 Li Battery charging stage curve

(1) Bulk Charging

In this stage, the battery voltage has not yet reached boost voltage, the controller operates in constant current mode, delivering its maximum current to the batteries (MPPT Charging).

(2) Boost Charging

When the battery voltage reaches the boost voltage set point, the controller will start to operate in constant charging mode, this process is no longer MPPT charging, and in the meantime the charging current will drop gradually, the process is not the MPPT charging. The Boost stage maintain 2 hours in default. When the accumulate time reach to 2hours, the charging mode will turn to Float charging.

(3) Float Charging

After the boost voltage stage, the controller will reduce charging current to Float Voltage set point. This stage will have no more chemical reactions and all the charge current transforms into heat and gas at this time. Then the controller reduces the voltage to the floating stage, charging with a smaller voltage and current. It will reduce the temperature of the battery and prevent the gassing and charging the battery slightly at the same time. The purpose of Float stage is to offset the power consumption caused by self consumption and small loads in the whole system, while maintaining full battery storage capacity.

In Float charging stage, loads are able to obtain almost all power from solar panel. If loads exceed the power, the controller will no longer be able to maintain battery voltage in Float charging stage. If the battery voltage remains below the Recharge Voltage, the system will leave Float charging stage and return to Bulk charging stage.

2 Installation Instructions

2.1 General Installation Notes

■ Please read the entire installation instructions to get familiar with the

installation steps before installation.

- Be very careful when installing the batteries, especially flooded lead-acid battery. Please wear eye protection, and have fresh water available to wash and clean any contact with battery acid.
- Keep the battery away from any metal objects, which may cause short circuit of the battery.
- Explosive battery gases may come out from the battery during charging, so make sure ventilation condition is good.
- Ventilation is highly recommended if mounted in an enclosure. Never install the controller in a sealed enclosure with flooded batteries! Battery fumes from vented batteries will corrode and destroy the controller circuits.
- Loose power connections and corroded wires may result in high heat that can melt wire insulation, burn surrounding materials, or even cause fire. Ensure tight connections and use cable clamps to secure cables and prevent them from swaying in mobile applications.
- Lead-acid battery and lithium battery are recommended, other kinds please refer to the battery manufacturer.
- Battery connection may be wired to one battery or a bank of batteries. The following instructions refer to a singular battery, but it is implied that the battery connection can be made to either one battery or a group of batteries in a battery bank.
- Multiple same models of controllers can be installed in parallel on the same battery bank to achieve higher charging current. Each controller must have its own solar module(s).
- When selecting connection wires for the system, follow the criterion that the current density is not larger than 5A/mm².

2.2 PV Array Requirements

(1) Serial connection (string) of PV modules

As the core component of PV system, controller could be suitable for various types of PV modules and maximize converting solar energy into electrical energy. According to the open circuit voltage (Voc) and the maximum power point voltage (VMpp) of the MPPT controller, the series number of different types PV modules can be calculated. The below table is for reference only.

Table 2-1 TD2107/TD2207/TD2307/TD2407

System voltage	36 cell Voc < 23V		48 cell Voc < 31V		54 cell Voc < 34V		60 cell Voc < 38V	
	Max.	Best	Max.	Best	Max.	Best	Max.	Best
12V	3	2	2	1	2	1	2	1
24V	3	2	2	2	2	2	2	2

System voltage	72 cell Voc < 46V		96 cell Voc < 62V		Thin-Film Module Voc > 80V
	Max.	Best	Max.	Best	
12V	1	1	1	1	-
24V	1	1	1	1	-

NOTE: The above parameter values are calculated under standard test conditions (STC (Standard Test Condition) : Irradiance 1000W/m², Module Temperature 25°C, Air Mass1.5.)

(2) Maximum PV array power

The MPPT controller has the function of current/power-limiting, that is, during the charging process, when the charging current or power exceeds the rated charging current or power, the controller will automatically limit the charging current or power to the rated charging current or power, which can effectively protect the charging parts of controller, and prevent damages to the controller due to the connection of some over-specification PV modules. The actual operation of PV array is as follows:

Condition 1:

Actual charging power of PV array ≤ Rated charging power of controller

Condition 2:

Actual charging current of PV array ≤ Rated charging current of controller

When the controller operates under "Condition 1" or "Condition 2", it will carry out the charging as per the actual current or power; at this time, the controller can work at the maximum power point of PV array.

⚠ WARNING: When the power of PV is not greater than the rated charging power, but the maximum open-circuit voltage of PV array is more than 75V(at the lowest environmental temperature), the controller may be damaged.

Condition 3:

Actual charging power of PV array > Rated charging power of controller

Condition 4:

Actual charging current of PV array > Rated charging current of controller

When the controller operates under "Condition 3" or "Condition 4", it will carry out the charging as per the rated current or power.

⚠ WARNING: When the power of PV module is greater than the rated charging power, and the maximum open-circuit voltage of PV array is more than 75V(at the lowest environmental temperature), the controller may be damaged.

According to "Peak Sun Hours diagram", if the power of PV array exceeds the rated charging power of controller, then the charging time as per the rated power will be prolonged, so that more energy can be obtained for charging the battery. However, in the practical application, the maximum power of PV array

shall be not greater than 1.5 x the rated charging power of controller. If the maximum power of PV array exceeds the rated charging power of controller too much, it will not only cause the waste of PV modules, but also increase the open-circuit voltage of PV array due to the influence of environmental temperature, which may make the probability of damage to the controller rise. Therefore, it is very important to configure the system reasonably. For the recommended maximum power of PV array for this controller, please refer to the table below:

Table 2-2 maximum power of PV array for this controller

Model	Rated Charge Current	Rated Charge Power	Max. PV Array Power	Max. PV open circuit voltage
TD2107	15A	190W/12V 380W/24V	285W/12V 570W/24V	70V ^① 75V ^②
TD2207	20A	260W/12V 520W/24V	390W/12V 780W/24V	
TD2307	30A	390W/12V 780W/24V	580W/12V 1170W/24V	
TD2407	40A	520W/12V 1040W/24V	780W/12V 1560W/24V	

①At 25°C environment temperature

②At minimum operating environment temperature

2.3 Wire Size

The wiring and installation methods must conform to all national and local electrical code requirements.

PV Wire Size

Since PV array output can vary due to the PV module size, connection method or sunlight angle, the minimum wire size can be calculated by the $I_{sc} *$ of PV array. Please refer to the value of I_{sc} in the PV module specification. When PV modules connect in series, the I_{sc} is equal to a PV modules I_{sc} . When PV modules connect in parallel, the I_{sc} is equal to the sum of the PV module's I_{sc} . The I_{sc} of the PV array must not exceed the controller's maximum PV input current. Please refer to the table as below:

NOTE: All PV modules in a given array are assumed to be identical.

* I_{sc} =short circuit current(amps) V_{oc} =open circuit voltage.

Table 2-3 PV array must not exceed the controller's maximum

Model	Max.battery wire size	Max. PV wire size *
TD2107	10mm ² /8AWG	10mm ² /8AWG
TD2207	10mm ² /8AWG	10mm ² /8AWG
TD2307	16mm ² /6AWG	16mm ² /6AWG
TD2407	16mm ² /6AWG	16mm ² /6AWG

* These are the maximum wire sizes that will fit the controller terminal

2.4 Mounting

⚠ Warning: risk of explosion! Never install the controller and an open battery in the same enclosed space! Nor shall the controller be installed in an enclosed space where battery gas may accumulate.

⚠ Warning: danger of high voltage! Photovoltaic arrays may produce a very high open-circuit voltage. Open the breaker or fuse before wiring, and be very careful during the wiring process.

Note: when installing the controller, make sure that enough air flows through the controller's radiator, and leave at least 100mm of space both above and below the controller so as to ensure natural convection for heat dissipation. If the controller is installed in an enclosed box, make sure the box delivers reliable heat dissipation effect.

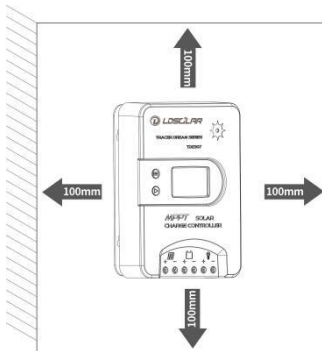

Figure 2-1 Mounting

2.5 Installation Procedure

Step 1: choose the installation site

Do not install the controller at a place that is subject to direct sunlight, high temperature or water intrusion, and make sure the ambient environment is well ventilated.

Step 2: first place the installation guide plate at a proper position, use a screw driver to mark the mounting points, then drill 4 mounting holes at the 4 marked points, and fit screws in.

Step 3: fix the controller

Aim the controller's fixing holes at the screws fit in Step 2 and mount the controller on.

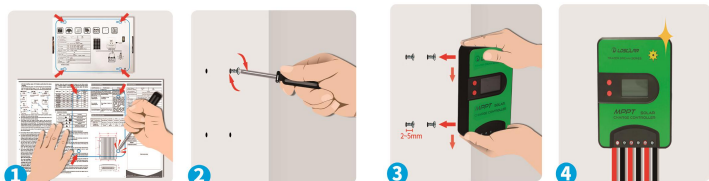

Figure 2-2 Installation Guide

⚠ CAUTION: If the controller is to be installed in an enclosed box, it is important to ensure reliable heat dissipation through the box.

Step 4: wire

Connect the system in the order of ① battery ② PV array ③ load in accordance with Figure 2-2, "Schematic Wiring Diagram" and disconnect the system in the reverse order ③②①.

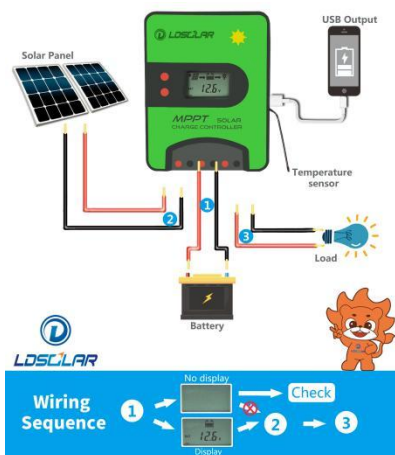

Figure 2-3 Schematic of wiring diagram

⚠ CAUTION: While wiring the controller do not close the circuit breaker or fuse and make sure that the leads of "+" and "-" poles are connected correctly.

⚠ CAUTION: A fuse which current is 1.25 to 2 times the rated current of the controller, must be installed on the battery side with a distance from the battery not greater than 150 mm.

⚠ CAUTION: If an inverter is to be connected to the system, connect the inverter directly to the battery, not to the load side of the controller.

Step 5: Power on the controller

After connecting all power wires solidly and reliably, check again whether wiring is correct and if the positive and negative poles are reversely connected. After confirming that no faults exist, first close the fuse or breaker of the battery, then see whether the LED indicators light up and the LCD screen displays information. If the LCD screen fails to display information, open the fuse or breaker immediately and recheck if all connections are correctly done.

If the battery functions normally, connect the solar panel. If sunlight is intense enough, the controller's charging indicator will light up or flash and begin to charge the battery.

After successfully connecting the battery and photovoltaic array, finally close the fuse or breaker of the load, and then you can manually test whether the load can be normally turned on and off. For details, refer to information about load working modes and operations.

⚠ Warning: when the controller is in normal charging state, disconnecting the battery will have some negative effect on the DC loads, and in extreme cases, the loads may get damaged.

⚠ Warning: within 10 minutes after the controllers stops charging, if the battery's poles are reversely connected, internal components of the controller may get damaged.

Note:

- 1) If no remote temperature sensor is connected to the controller, the battery temperature value will stay at 25 °C.
- 2) If an inverter is deployed in the system, directly connect the inverter to the battery, and do not connect it to the controller's load terminals.

3. Operation

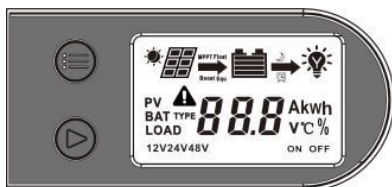

3.1 Button

Mode	Note
Load ON/OFF	In load manual mode, it can turn the load On/Off via the "OPERATION" button (▶).
Clear Fault	Press the "OPERATION" button (▶).
Browsing Mode	Press the "MENU" button (☰).
Setting Mode	Press the "MENU" button. and hold on 5s to enter the setting mode Press the "OPERATION" button. to set the parameters, Press the "MENU" button. to confirm the setting parameters or no operation for 10s, it will exit the setting interface automatically.

3.2 Interface

(1) Status Description

Item	Icon	Status
PV array		In daytime and PV connected correctly
		At night or no PV connect or reverse connect
		No Charging
		Charging In MPPT
		In Float Charging Mode
		In Boost Charging Mode
	PV	PV Voltage, Current and Power
Battery		Battery Capacity Indicating
	12V24V48V	Current System Voltage
	BAT	Battery Voltage and Current
	BAT TYPE	Battery Type
Load		Load ON
		Load OFF
		Light and Time Control Mode
		Light Control Mode
	LOAD TYPE	Load Working Mode
	LOAD	Discharging Current and Work Status

(2) Fault Indication

Status	Icon	Description
Battery over discharged		Battery level shows empty, battery frame blink, fault icon blink
Battery over voltage		Battery level shows full, battery frame blink, fault icon blink
Controller over temperature		Temp.icon shows Temp.inside controller is higher than 75℃, temperature icon blink, fault icon blink
Load failure		Load overload①, Load short circuit
PV over voltage		It shows PV voltage is higher than rated PV open voltage.PV icon blink,fault icon blink

(3) Browse interface

①If there is no operation within 20s in any interface or after powered on within 10s, The main interface will cycle to display the battery voltage,PV voltage,charging current,discharging current and battery temperature every 3s.Long press the “OPERATION ” button (🔴) can speed up the cycle display time.

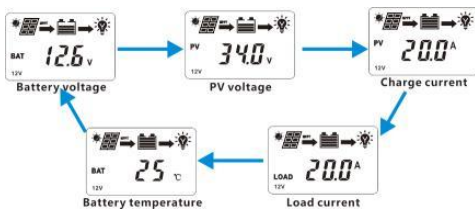

②At main interface(cycle display),long press **menu** and **operation** button at same time to enter working record status,it can show times of low voltage,working days,times of over current and times of full charging

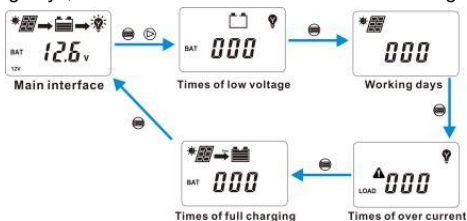

③At main interface(cycle display),Press the “MENU” button(⊞) and enter menu interface

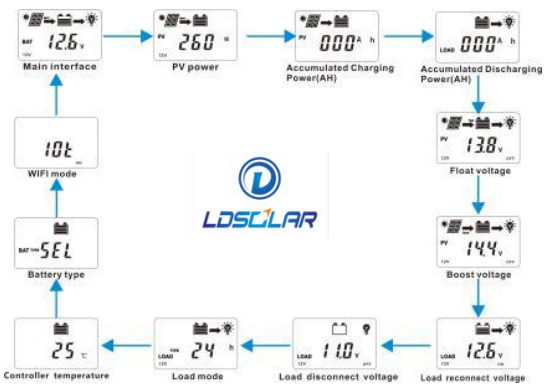

3.3 Setting

(1) Clear the charging power and discharging power(AH)

Operation:

Step 1: Press the “MENU” button and hold for 5s under the PV generated charging power interface and the value will be cleared.

Step 2: Press the “MENU” button and hold for 5s under the PV generated discharging power interface and the value will be cleared

(2) Float Voltage Setting

Operation:

Step 1: At main interface(cycle display),Press the “MENU” button to enter float voltage interface

Step 2: Long press the “MENU” button($\geq 5S$) until the value is flashing,then it enters the setting state.

Step 3: Press the “MENU” and “OPERATION” button to change the value

Step 4: After setting,Long press the “MENU” button($\geq 5S$) to save the new setting.If there is no operation within 20S,the controller will enter the main interface and cycle to display automatically.

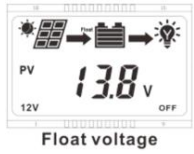

(3) Setting of boost voltage, low voltage reconnect voltage and low voltage disconnect voltage



Low Voltage Disconnection Voltage



Low Voltage Reconnection Voltage

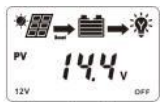

Boost voltage

Operation:At main interface(cycle display),Press the “MENU” button to enter the relevant interface below:

The operation method of setting is the same as float voltage setting,Please refer to the above”(2)”.

■ **The following rules must be observed when modifying the parameter values in User**

I .Charging Limit Voltage >Boost Charging Voltage >Float Charging Voltage > Boost Reconnect Charging Voltage.

II .Low Voltage Reconnect Voltage > Low Voltage Disconnect Voltage(BMS+0.2V)

III. Boost Reconnect Charging voltage > Low Voltage Load Reconnect Voltage> Low Voltage Disconnect Voltage(BMS+0.2V)

■ **Battery Voltage Control Parameters**

Below parameters are in 12V system at 25 °C, please double the values in 24V system

Battery Type	SEL 24V*2	GEL 24V*2	FLD 24V*2	LF4(LiFePO44S/12V)) LF8 (LiFePO4 8S/24V*2)	LI3 (Li(NiCoMn)O 2 3S/12V)	LI7 (Li(NiCoMn)O 2 7S/24V)
Over Voltage Disconnect	16.0V	16.0 V	16.0 V	16.0V	17.0 V	32.0V
Charging Limited Voltage	15.0 V	15.0 V	15.0 V	14.8V	17.0 V	30.0V
Over Voltage Reconnect	15.0 V	15.0 V	15.0 V	14.8V	17.0 V	30.0V
Boost charge	14.4 V	14.2 V	14.6 V	14.6V	12.6V	29.4V
Float charge	13.8 V	13.8 V	13.8 V	14.4V	12.4V	29.0V
Boost Restart Voltage	12.6V	12.6V	12.6V	13.0V	11.5V	26.0V
Low voltage reconnect	12.6V	12.6V	12.6V	12.6V	11.0V	25.2V
Low voltage disconnect	11.0V	11.0V	11.0V	10.5V	9.0V	21.0V

(4) Load Working Mode

The default working mode of the controller is 24 hours,which means that as long as the battery has enough energy, the controller can supply power to the load continuously.

Operation:

Step 1: At main interface(cycle display),Press the “MENU” button to enter

load mode interface.

Step 2: Long press the “MENU” button(≥5S) until the 24H is flashing,then it enters the setting state.

Step 3: Press the “MENU” and “OPERATION” button to change the value

Step 4: After setting,Long press the “MENU” button(≥5S) to save the new setting.If there is no operation within 20s,the controller will enter the main interface and cycle to display automatically.

Hours	Light and Timer Control
24H	Load will always be on
1H	Load will be on for 1 hour after sunset
2H	Load will be on for 2 hours after sunset
3H~14H	Load will be on for 3 ~ 14hours after sunset
14H~23H	Load will be on after sunset and be off before sunrise.

(5) Battery type

①support battery types

Lead-acid battery	Sealed(default)/Gel/Flooded/User
Lithium battery	LiFePO4 LF4/12V;LF8/24V;
	Li(NiCoMn)O2 LI3/12V;LI7/24V;

②Setting the battery type via LCD

Step 1: At main interface(cycle display),Press the “MENU” button to enter battery type mode interface.

Step 2: Long press the “MENU” button(≥5S) until the “SEL” is flashing,then it enters the setting state.

Step 3: Press the “MENU” and “OPERATION” button to confirm the battery type below:

Step 4: Long press the “MENU” button(≥5S) to save the new setting.If there is no operation within 20S,the controller will enter the main interface and cycle to display automatically.

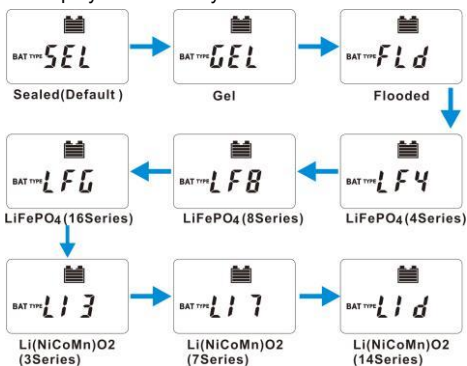

(6)Bluetooth Module

Step 1:Turn on the Bluetooth switch of the mobile phone, and open the iConnect App-- select wireless communication--device--communication selection-Bluetooth.

Step 2:Click the “Search Device” button--select the device whose name begins with BT04--enter the password 0000/1234-- connection succeeded.

(7) WiFi Mode

WiFi mode is divided to WiFi direct connection mode and WiFi networking IOT mode(default)

①How to switch to WiFi direct connection?

Step 1: Press the Menu button of the controller to select the communication mode design interface.

Step 2: Hold down the“MENU”button,then press the operation button once,.Two seconds later, the LCD display will switch from IOT to AP,Then release the “MENU”button.It has switched to WiFi direct connection mode.

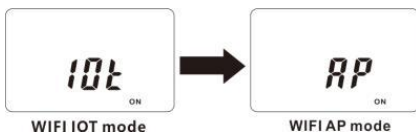

②How to switch back to WiFi networking IOT mode?

Press the Menu button of the controller to enter the WiFi setting interface, press the operation button, and the LCD display will switch from AP to IOT,then switch to the WiFi networking IOT mode.

③How to enter configuration state

Press the “MENU”button to enter WiFi mode interface(shows on the right).then press and hold the “MENU”button for more than 10s, LCD interface switches and flashed between IOT and AP interface.Now it enters the distribution network state.



•How to connect WiFi with app? Please scan the QR code on the left with the browser. And refer to the instructions of iConnect app 2.2.3/3.2.1

•In Wi-Fi direct connection mode, the Wi-Fi connected to the mobile phone can't connect to the Internet, so App upgrade and mobile phone WiFi Internet access are not available.

•If your controller is equipped with external WiFi module, please operate on the external WiFi module. Please refer to the external WiFi module's manual for details.

(8) App Setting

All the above settings can be set through the iConnect app, but the controller needs to be equipped with Bluetooth or WiFi module

①App Download

•Android/Harmony System

Method 1: Scan the following QR code with your mobile browser and enter the App download page. Click the latest version of the download file directly, and then install it directly (if prompted during the installation process, please select "Trust" and "Allow" to continue the installation. Harmony system should not turn on pure mode)



Method 2: The mobile phone web page can be downloaded and installed directly by logging in to <https://www.ldsolarpv.com/jszc#> or <https://www.ldsolar.com/download>.



Method 3: Google Play application market download

Search for "LD iConnect" in Google Play Application market and find Idsolar's app. The icon is as follows. Just download and install it directly.

•IOS for Apple

Search for "LD iConnect" in the Apple store, and find Idsolar's app, with the icon above, just download and install it directly.

Note:

•After downloading the App, please check the application update in My iConnect -- click Automatic Update to the latest version. In this way, you can enjoy the latest application functions.

②Installation of communication module

If equipped with inbuilt communication module, it does not need to be installed. The external Bluetooth or WiFi module needs to be equipped with a controller with RJ45 interface. After the controller is connected in the system successfully, plug the module into the RJ45 interface and the indicator light on the module will be on.

③How to use App?

Please refer to the instruction manual of iconnect app for details. Scan the QR code or download from the iConnect App



3.4 Accessories (optional)

(1) Built-in WiFi module

After the controller is equipped with the built-in WiFi module, the operation and related parameters of the controller can be monitored by the mobile iConnect App through WiFi signal.

(2) Built-in Bluetooth module

After the controller is equipped with the built-in Bluetooth module, the operation and related parameters of the controller can be monitored by the mobile iConnect App

NOTE: For more setting and operation of the module, please refer to iConnect App user manual.

4. Protections, Troubleshooting and Maintenance









4.1 Protection

<p>PV Over Current/power</p>	<p>When the charging current or power of the PV array exceeds the controller's rated current or power, it will be charged at the rated current or power. NOTE: When the PV modules are in series, ensure that the open-circuit voltage of the PV array does not exceed the "maximum PV open-circuit voltage" rating. Otherwise the controller may be damaged.</p>
<p>PV Short Circuit</p>	<p>When not in PV charging state, the controller will not be damaged in case of a short-circuiting in the PV array.</p>
<p>PV Reverse Polarity</p>	<p>When the polarity of the PV array is reversed, the controller may not be damaged and can continue to operate normally after the polarity is</p>

	corrected.
Night Reverse Charging	Prevents the battery from discharging through the PV module at night.
Battery Reverse Polarity	Fully protected against battery reverse polarity; no damage will occur for the battery. Correct the wrong wiring to resume normal operation. NOTE: Limited to the characteristic of lithium battery, when the PV connection is correct and battery connection reversed, the controller will be damaged.
Battery Over Voltage	When the battery voltage reaches the over voltage disconnect voltage, it will automatically stop battery charging to prevent battery damage caused by over-charging.
Battery Over Discharge	When the battery voltage reaches the low voltage disconnect voltage, it will automatically stop battery discharging to prevent battery damage caused by over-discharging. (Any controller connected loads will be disconnected. Loads directly connected to the battery will not be affected and may continue to discharge the battery.)
Load Short Circuit	When the load is short circuited (The short circuit current is ≥ 2 times the rated controller load current), the controller will automatically cut off the output. The controller will reconnect the output automatically every 30s to judge whether the short circuit is relieved, it needs to be cleared by pressing the operation button or restarting the controller.
Load Overload	When the load is overloading (The overload current is ≥ 1.1 times the rated load current), the controller will automatically cut off the output. If the load reconnects automatically every 30s, it needs to be cleared by pressing the Load button restarting the controller or restarting the controller.
Controller Overheating	The controller is able to detect the temperature inside the battery. The controller stops working when its temperature exceeds 85°C and restart to work when its temperature is below 65°C .
TVS High Voltage Transients	The internal circuitry of the controller is designed with Transient Voltage Suppressors (TVS) which can only protect against high-voltage surge pulses with less energy. If the controller is to be used in an area with frequent lightning strikes, it is recommended to install an external surge arrester.

★When the internal temperature is 75°C , the reducing power charging mode which reduce the charging power of 5% every increase 1°C is turned on. If the internal temperature is greater than 85°C , the controller will stop charging. When the temperature declines to be below 65°C , the controller will resume.

4.2 Troubleshooting

Possible reasons	Faults	Troubleshooting
PV array disconnection	LCD display during daytime 	Confirm that PV wire connections are correct and tight.
Battery voltage is lower than 8V	Wire connection is correct, the controller is not working.	Please check the voltage of battery. At least 8V voltage to activate the controller.
Battery over voltage	  Battery level shows full, battery frame blink, fault icon blink	Check if battery voltage is higher than OVD(over voltage disconnect voltage), and disconnect the PV.
Battery over discharged	  Battery level shows empty ,battery frame n blink	When the battery voltage is restored to or above LVR(low voltage reconnect voltage), the load will recover
Load Overload	   1. The load is no output	①Please reduce the number of electric equipments. ②Restart the controller.
Load Short Circuit	2.Load and fault icon blink	①Check carefully loads connection, clear the fault. ②Restart the controller.

4.3 Maintenance

The following inspections and maintenance tasks are recommended at least two times per year for best performance.

- Make sure controller firmly installed in a clean and dry ambient.
- Make sure no block on air-flow around the controller. Clear up any dirt and fragments on radiator.
- Check all the naked wires to make sure insulation is not damaged for solarization, frictional wear, dryness, insects or rats etc. Repair or replace some wires if necessary.
- Tighten all the terminals. Inspect for loose, broken, or burnt wire connections.
- Check and confirm that LED is consistent with required. Pay attention to any troubleshooting or error indication. Take corrective action if necessary.
- Confirm that all the system components are ground connected tightly and correctly.
- Confirm that all the terminals have no corrosion, insulation damaged, high temperature or burnt/discolored sign, tighten terminal screws to the suggested torque.
- Check for dirt, nesting insects and corrosion. If so, clear up in time.
- Check and confirm that lightning arrester is in good condition. Replace a new one in time to avoid damaging of the controller and even other equipments.

⚠WARNING: Risk of electric shock!

Make sure that all the power is turned off before above operations, and then follow

the corresponding inspections and operations.

5. Technical Specifications

5.1 Electrical Parameters

Item	TD2107	TD2207	TD2307	TD2407
System nominal voltage	12/24VDC		Auto ①	
Rated charge current	15A	20A	30A	40A
Rated discharge current	15A	20A	30A	40A
Battery voltage range	8 ~ 32V			
Max. PV open circuit voltage	② 75V ③ 70V			
MPP voltage range	(Battery voltage +2V) ~ 65V			
Battery Type	Sealed(Default)/Gel/Flooded/LiFePO4/ Li(NiCoMn)O2/ User			
Max. PV input power	190W/12V 380W/24V	260W/12V 520W/24V	390W/12V 780W/24V	520W/12V 1040W/24V
LVD	11.0V ADJ 9V....12V; ×2/24V;			
LVR	12.6V ADJ 11V....13.5V; ×2/24V;			
Float voltage	13.8V ADJ 13V....15V; ×2/24V;			
Boost voltage	14.4V ; ADJ14V....17V; ×2/24; Battery Voltage less than Boost Restart Voltage Start Boost changing for 2hours			
Self-consumption	≤28mA(12V) ≤19mA(24V)			
Discharge circuit voltage drop	≤0.12V			
Temperature compensate Coefficient ④	-4mv/°C/2V			

①When a lithium battery is used, the system voltage can't be identified automatically.

②At minimum operating environment temperature

③At 25°C environment temperature

④When a lithium battery is used, the temperature compensate coefficient will be 0.

5.2 Environmental Parameters

Working environment temperature ◆	-20°C ~ +50°C (100% input and output)
Storage temperature range	-20°C ~ +70°C
Relative humidity	≤95%, N.C.
Enclosure	IP30

◆The controller can work under full load in the working environment temperature, When the internal temperature is more than 80°C, the reducing power charging mode is turned on.

5.3 Mechanical Parameters

Item	TD2107	TD2207	TD2307	TD2407
Dimension	165×123×46 mm	195×123×46 mm	205×157×53 mm	256×157×53 mm
Mounting Dimension(A*B)	106×124mm	106×124mm	138×124mm	138×155mm
Mounting hole size	Φ4mm			
Weight	0.56KG	0.73KG	1.2KGS	1.5KGS

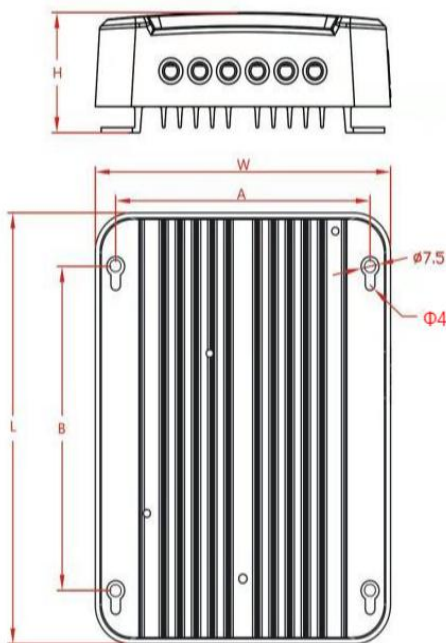

LD SOLAR

Any changes without prior notice

Version:TD75V V2.2

Your battery guard